

A-FRAME[®]

TRACKER INTERFACE

VERSION 2.0

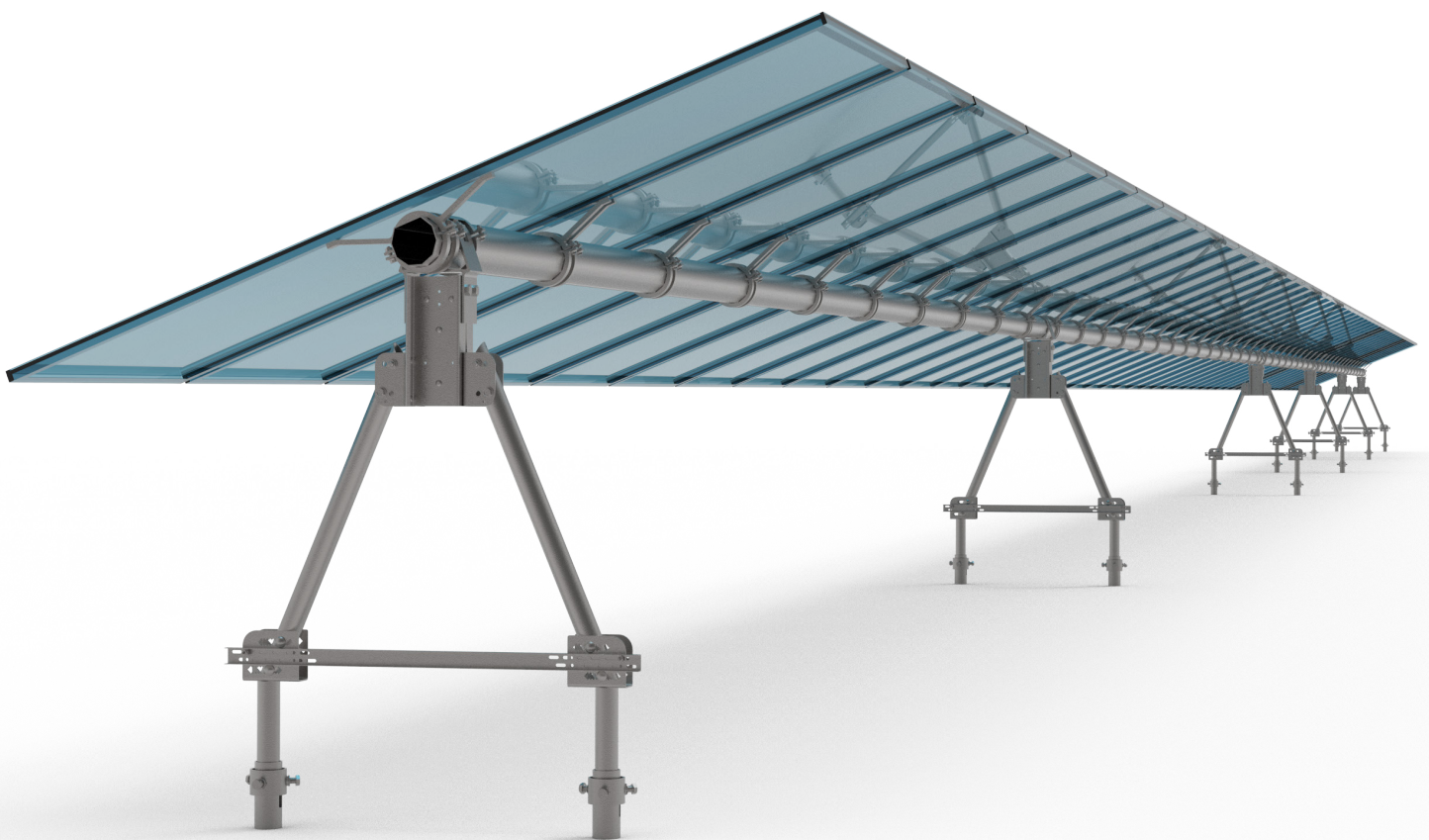

TABLE OF CONTENTS**PAGE**

2	TABLE OF CONTENTS
3	PARTS LIST
4	SITE PREPARATION, UTILITIES, SURVEYING, TOOLS
5	REVIEW & INSTALLATION PREPARATION, UNEVEN GROUND, MEASURING
6	FOUNDATION INSTALLATION, ALTERNATE FOUNDATION INSTALLATION
7	A-FRAME® INSTALLATION
8	A-FRAME® INSTALLATION (CONTINUED)
9	RIGID BRACING
10	SEISMIC BRACING, QUALITY CHECKS
11	PRO-TIPS
12	O&M REQUIREMENTS
13	O&M REQUIREMENTS
14	O&M REQUIREMENTS
15	USA GROUND SCREW ADDENDUM A

PARTS LIST

STRUCTURAL MEMBERS

- [1] HELICAL OR SCREW FOUNDATION
- [2] LEVELING FLANGE (RISER TUBE)
- [3] STANDARD A-FRAME® (PIER)
- [4] DAMPER A-FRAME® (PIER)
- [5] GEAR RACK A-FRAME® OR MOTOR A-FRAME® (PIER)
- [6] CROSS BRACE

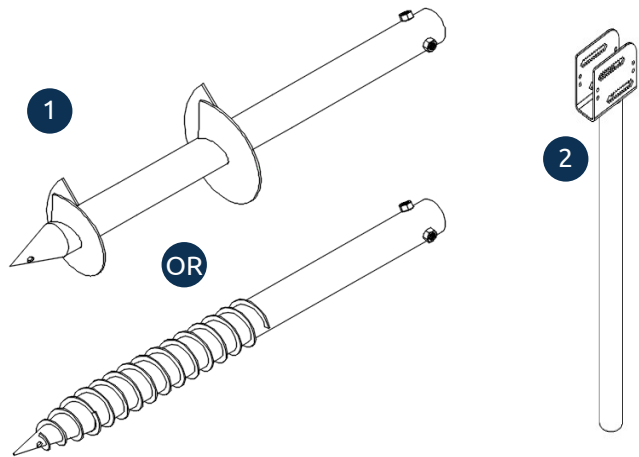

HARDWARE

- [7] 5/16-18 X 3/4 SERRATED HEX WASHER HEAD BODY BOLT
- [8] 5/16-18X1.75" CARRIAGE BOLT
- [9] 5/16-18 SERRATED FLANGE NUT
- [10] 5/16-18 HEX NUT
- [11] 1/2-13X1.0" SERRATED FLANGE BOLT
- [12] 1/2-13X3.5" CARRIAGE BOLT
- [13] 1/2-13 SERRATED FLANGE NUT
- [14] M16X2.0 30MM HEX BOLT (SET BOLT)
- [15] 1/4-20X1.75" U-BOLT
- [16] 1/4-20 SERRATED FLANGE NUT
- [17] 1/2-13X3.5" SERRATED FLANGE BOLT
- [18] CABLE BRACING
- [19] TUBE CLAMP
- [20] GRIPPLE

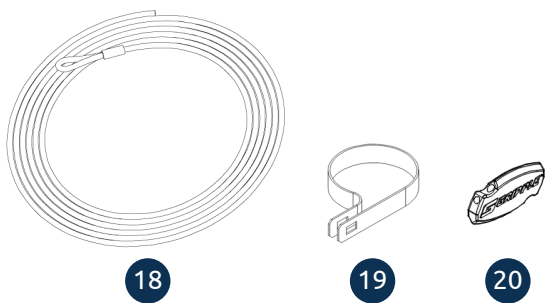
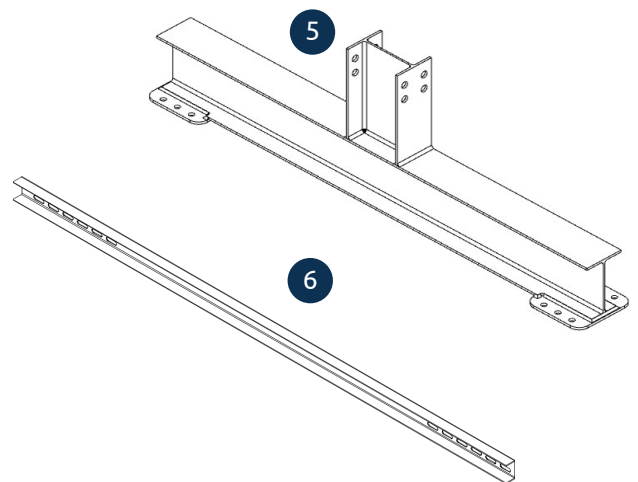
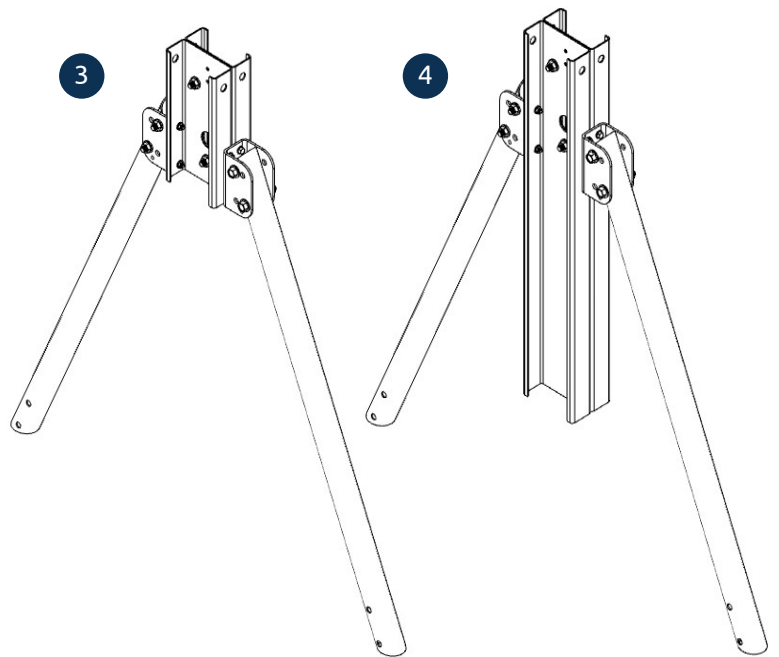

NOTE

A-Frame® designs vary based on tracker manufacturer.

CONSTRUCTION 101

All structures, regardless of how complex, are built one step at a time. Each new step builds on the previous. In order for the final structure to be complete, it is best to ensure that each step is done correctly. It is far easier, faster, and cheaper to take your time to ensure each step is done correctly before moving on. There is no remedy for an error other than a correction. Time and effort will be put forth eventually to redo steps, reconstruct, and make adjustments, but far less effort is required to correct mistakes as they appear. If errors are fixed immediately, each subsequent step will begin correct and projects will run more efficiently.

It is recommended to completely install a test row from beginning-to-end of the row, and from beginning-to-end of all steps (from layout, to panel installation, and adjustments). This will help you understand not only how to install the product, but understand how tolerances stack up, how mistakes in one step cause errors in other steps, and how to make the adjustments required to keep everything in tolerance and looking good.

SITE PREPARATION

Site preparation should be conducted prior to construction. This will typically involve grubbing, rock and debris removal, and any other preparation that will facilitate swift and unhindered installation.

UTILITIES

All utilities should be marked before any construction begins.

SURVEYING

To ensure that the solar array is installed according to customer plans, the site should be surveyed according to the scope of work. This includes the North and South foundation locations for the A-Frame® system. For projects with significant topography, survey points should be checked with a tape measure. Typically, the A-Frame® system requires a 100% survey.

TOOLS

The M16 ground screw set bolts require a minimum 400 ft/lb impact gun. 1/2" hardware requires a minimum 300 ft/lb impact gun to have enough torque to tighten fully.

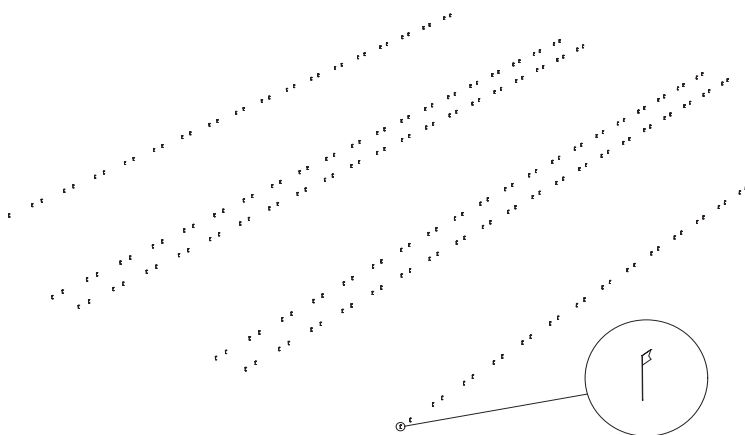

NOTE

Foundation locations should be surveyed by a professional surveyor, who can stake out row locations to the highest precision.

REVIEW & INSTALLATION PREPARATION

After site preparation has been completed and the site surveying is done, the foundations are ready to be installed. It is the responsibility of the site lead to review and understand the site foundation layout, surroundings, installation procedures, and to manage the installation to completion. Each project has different requirements (embedment depths, spans, etc.) that need to be met according to site testing and data gathered prior to the start of the project. The site lead must verify that the foundations on site match the order and project requirements.

Dimensions in the North-South direction will change depending on row length, row location, and location within the row. Closely follow the construction plans and if there are any questions or discrepancies, report them to the site lead or project manager before installing any foundations.

UNEVEN GROUND

For sites with ungraded or rolling topography, it is important to ensure that the foundations are set to the correct depths. In cases where post locations can not be marked on the ground (uneven terrain), it is advised to check the survey points with a steel tape measure.

MEASURING

All measurements in the North-South direction must be made with a steel tape measure, and made from the motor pier location, not foundation-to-foundation. For top of pile measurements the steel tape measure should be attached to the top of the motor A-Frame®, and checked at each top of pile location.

Measuring from foundation-to-foundation allows tolerances to stack up. In this case, a 2" tolerance would have stacked up to be 8" off by only the fifth foundation, and will cause major installation issues further down the road. If necessary, tape measures should be marked prior to use or prints should be marked up to indicate additive measurements (ie. 0", 25'11", 53', 80'2", 107'3").

For A-Frame® systems, the North and South points must remain in line with each other (one should not "chase" the other). Ensure the points are square every few sets by measuring diagonals. If marks are found to be out of square, make adjustments to correct.

For top of pile measurements the steel tape measure should be attached to the top of the motor A-Frame®, and checked at each top of pile location.

PRO TIP
I

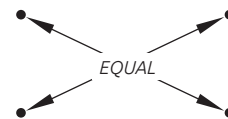

Measuring diagonals

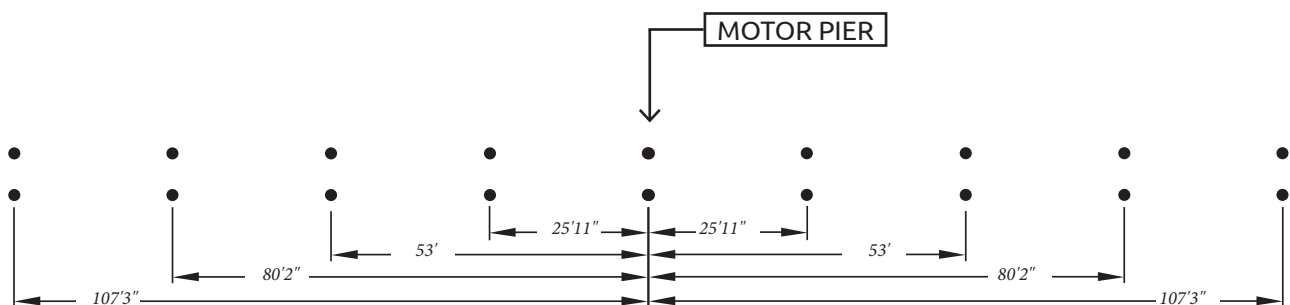

FOUNDATION INSTALLATION

1. Preinstall the set bolts to ensure the integrity of the welded nut.
2. Drive the foundation with a single point, starting at one end of the site. The string line method is best for ensuring a straight line and a perfect plane of the array.
3. Ensure the foundation is held plumb and in the proper location using a level.
4. Drive the foundation to the correct depth as indicated by the construction documents. Foundations are to be installed at a maximum 6" reveal above grade.
5. Install all remaining foundations, using a string line as a guide for placement and height if necessary. Use a tape measure as described in the preparation process.

ALTERNATE FOUNDATION INSTALLATION

For sites with medium-to-heavy rock or bedrock, holes may need to be drilled and backfilled prior to foundation install. When required, refer to the ground screw installation manual. - Drilled Hole

NOTE

For installation of EarthLock™ or USA Ground Screws, see addendum A

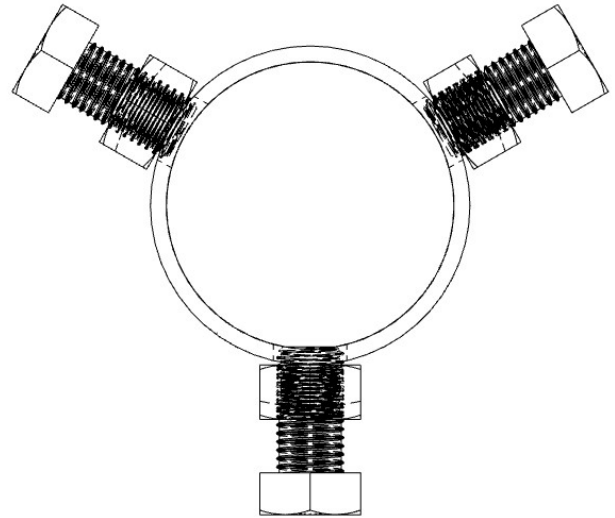

Top view of foundation and fully tightened M16 bolts

PRO TIP
2

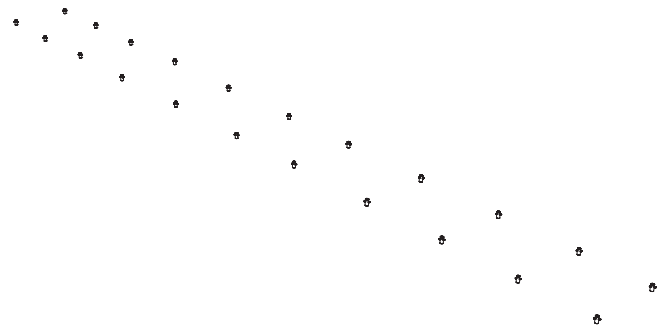

NOTE

Check all survey points before drilling.

Prior to installation, Nextracker's Construction Set and Installation Manual should be reviewed to ensure proper installation of the racking as a whole.

SETTING TOP OF PILE HEIGHTS WITH THE Z-VALUE

A Civil Engineer can provide an adjusted survey file that provides the X,Y, and Z-values for the entire site. This would allow leveling flanges to be set at a pre-determined height, reducing adjustments required during the installation of the tracker system.

This is not a service provided by APA and would require a 3rd party surveyor and Civil Engineer. If not available, proceed with the following recommended leveling flange installation method.

A-FRAME® (PIER) INSTALLATION

- [1] HELICAL OR SCREW FOUNDATION
- [2] LEVELING FLANGE (RISER TUBE)
- [3] STANDARD A-FRAME® (PIER)
- [6] CROSS BRACE
- [7] 5/16-18 X 3/4 SERRATED HEX WASHER HEAD BODY BOLT
- [9] 5/16-18 SERRATED FLANGE NUT
- [12] 1/2-13X3.5" CARRIAGE BOLT
- [13] 1/2-13 SERRATED FLANGE NUT
- [14] M16X2.0 30MM HEX BOLT (SET BOLT)
- [17] 1/2-13X3.5" SERRATED FLANGE BOLT

1. Insert the leveling flanges (riser tubes) into the foundation.
2. Attach the cross brace member with one bolt and nut in each riser. This helps to keep the riser bracket square during installation. The nut requires a 7/16" box end wrench to hold it in place while threading the self tapping bolt.
3. Starting with either the East or West side of riser tubes in the row, use a laser to manually adjust your plane. Once the plane is established, you can lightly tighten the set bolts on that side.
4. Using a 4' level, and a board if necessary due to wider than 4' spans, you can now set the other side of riser tubes by setting it on top and making it level to your laser adjusted side.
5. Add the remaining hardware for the cross brace-to-riser connection and tighten.
6. Layout the A-Frames® (piers) according to the plans for the solar tracker system. Note: there are different types of piers based on the tracker design. Make sure to check the pier plans carefully and layout the correct one in the correct location. A-Frames® will need to be opened from the stored position to the assembled position and the fasteners added.

PRO TIP
5

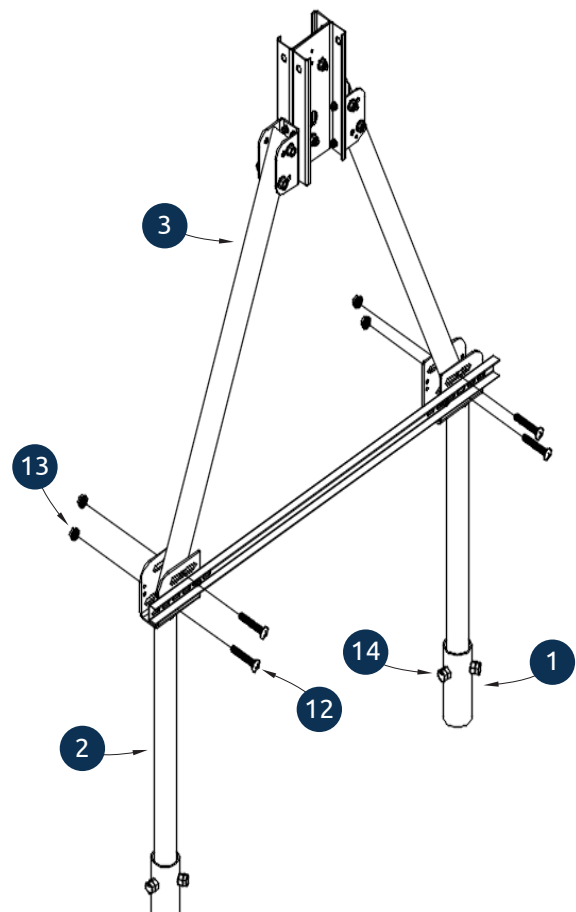
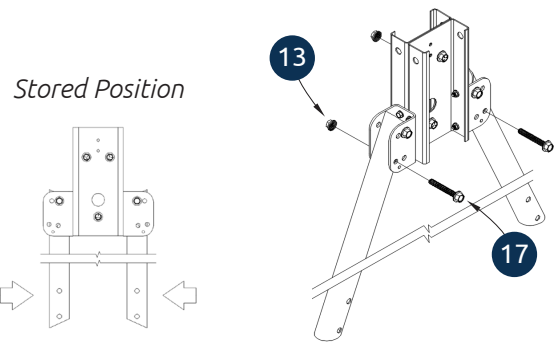
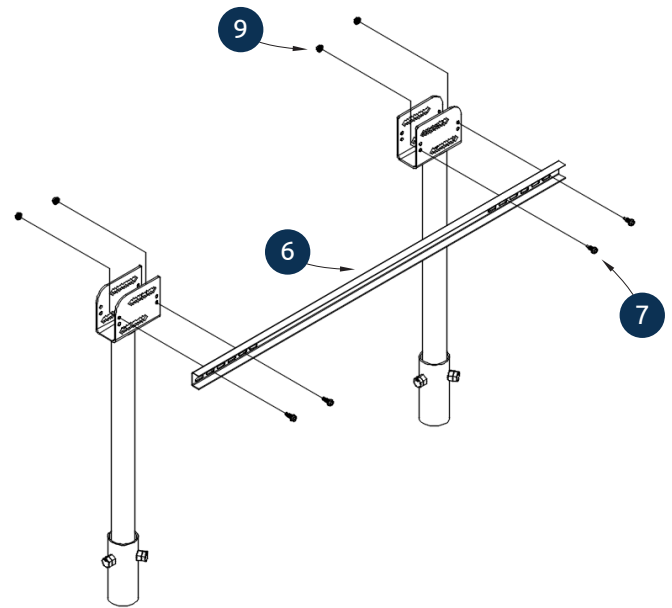

A-FRAME® INSTALLATION (CONTINUED)

7. Align end piers and transition piers as needed and loosely tighten. Place a string on the flat side of the I beam to create a straight line across the row.

8. Place the remaining piers on top of the riser tubes. Place the A-Frame® in the appropriate position within the riser bracket that best aligns with the string line and loosely connect the pier to the riser tubes.

9. Once the piers are aligned, fully tighten the A-Frames® to the risers using an impact gun capable of reaching the required torque for the connections. The set bolts on the ground screw should also be fully tightened at this point. Make sure to use a level on the A-Frame® I-Beam to check for plumbness while tightening.

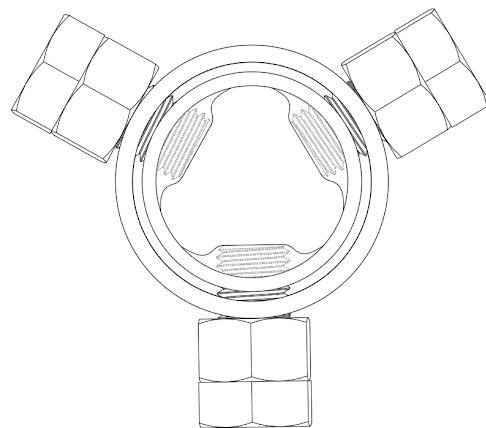

Top view of foundation and fully tightened M16 bolts

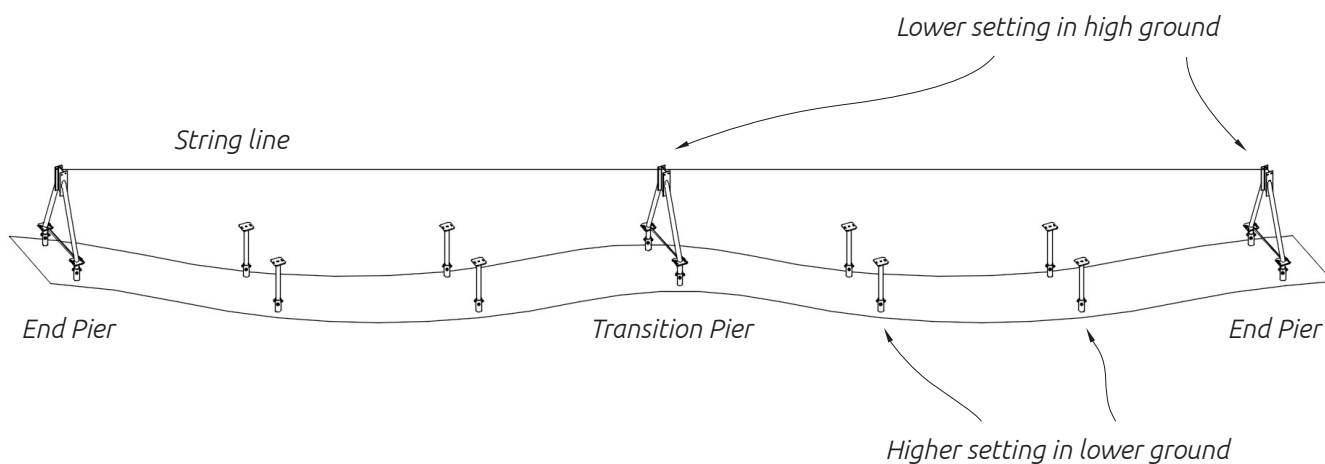

NOTE

If the ground is not flat, the pier(s) in higher areas should be set to the lowest position using the riser tubes, and all other piers in the row should be raised.

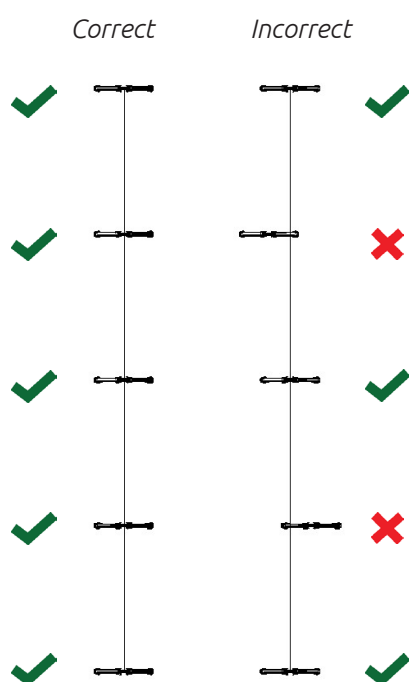

RIGID BRACE INSTALLATION (IF REQUIRED)

- [1] HELICAL OR SCREW FOUNDATION
- [2] LEVELING FLANGE (RISER TUBE)
- [5] WELDED A-FRAME®
- [13] 1/2-13 SERRATED FLANGE NUT
- [14] 1/2-13X3.5" SERRATED FLANGE BOLT
- [18] 1/2-13X3.5" CARRIAGE BOLT
- [22] RIGID BRACE BRACKET
- [23] RIGID BRACE LOWER
- [24] RIGID BRACE UPPER
- [25] 1/2-13X1.25" SERRATED FLANGE BOLT
- [26] 1/2-13X4" SERRATED FLANGE BOLT

1. Install the Rigid Brace Bracket to the A-Frame®.
2. Attach the Rigid Brace Upper to the Rigid Brace Bracket.
3. Install the Rigid Brace Lower to the upper so that it aligns with the Leveling Flange (Riser Tube).
4. Lift the Leveling Flange into position and Attach to the Rigid Brace.
5. Tighten the foundations set bolts to hold the Leveling Flange in place.
6. Tighten all hardware.

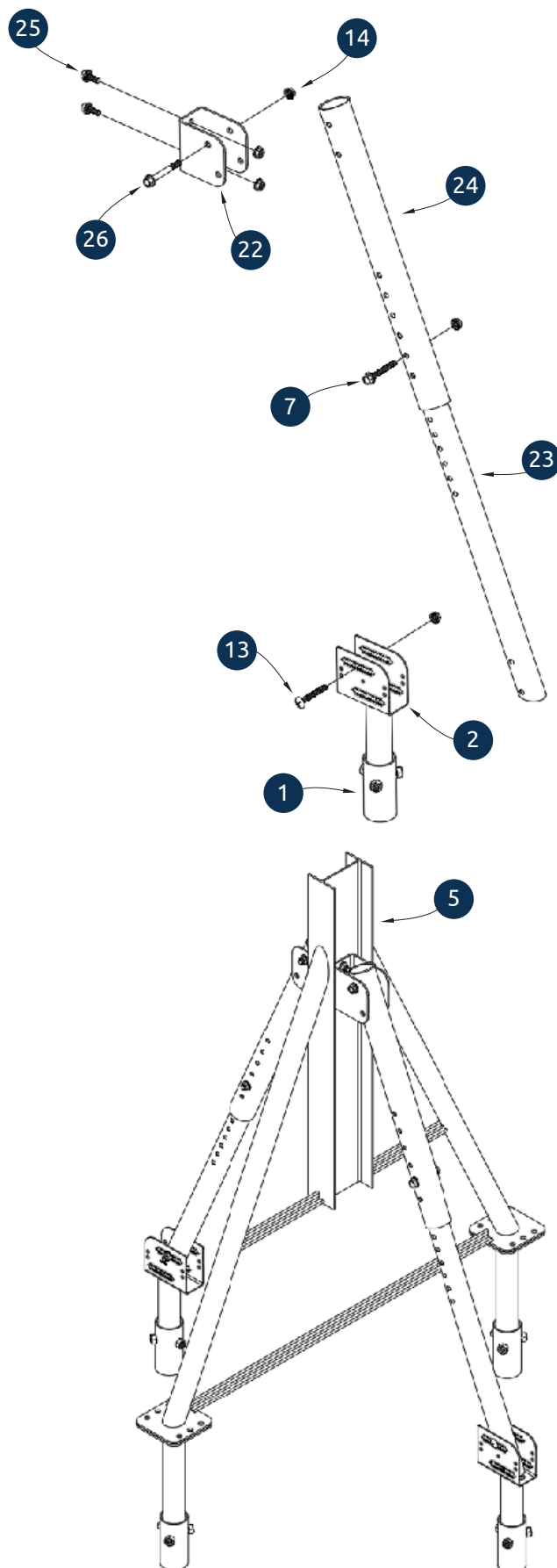

NOTE

Refer to the Construction Drawings for tolerances and specifications.

SEISMIC BRACING

- [1] HELICAL OR SCREW FOUNDATION
- [8] 5/16-18X1.75" CARRIAGE BOLT
- [10] 5/16-18 HEX NUT
- [15] 1/4-20X1.75" U-BOLT
- [16] 1/4-20 SERRATED FLANGE NUT
- [18] CABLE BRACING
- [19] TUBE CLAMP
- [20] GRIPPLE

1. Install the weak axis/seismic bracing according to the construction documents. Bracing should be installed loosely until the torque tube and bearing assemblies have been tightened at the top of the pier.
2. Slide the closed loop end of the cable bracing onto the u-bolt and fasten the u-bolt to the A-Frame® I-Beam.
3. Spread apart the tube clamp, slide it around the foundation, and recompress it.
4. Secure cables with bolts, loosely. Ensure that the bolts are pointing to the interior of the A-Frame®.
5. Connect the two cables using the gripple.
6. Use a gripple tensioning tool to tighten the cables taught.

QUALITY CHECKS

1. Ensure that all set bolts are fully seated.
2. Ensure that all 1/2" hardware is torqued to specifications in the build package.
3. Pier tolerances are dictated by the solar tracker system used. Please reference the plans provided by the solar tracker provider.
4. Additional, project-specific information may be provided in the build package. Please review carefully.
5. Ensure that all cross braces are properly installed at the correct locations.

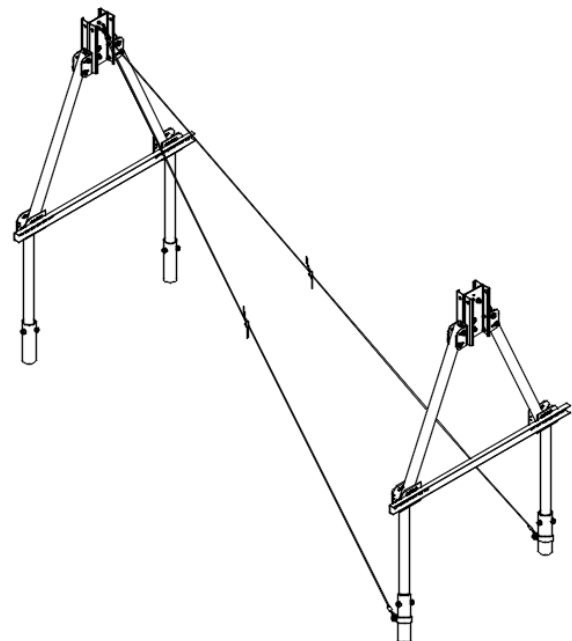
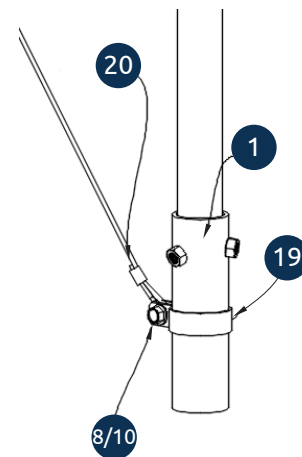
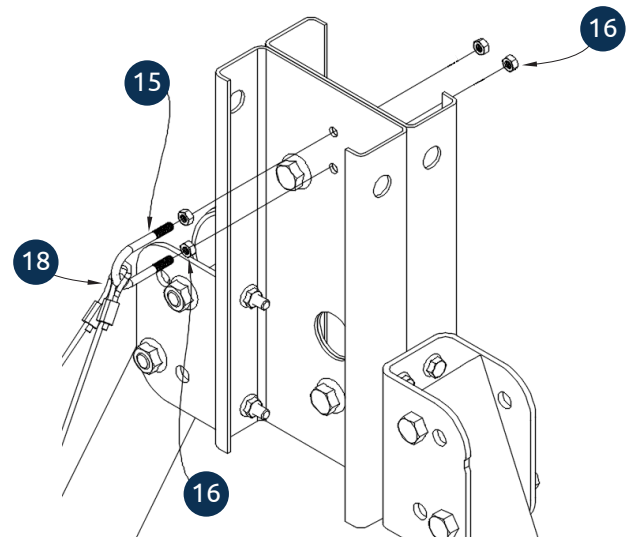

PRO TIPS

PRO TIPS are pieces of advice from installation experts. They are intended to provide practical solutions to real-world problems that you may encounter. Before implementing any of the below tips, make sure to request approval from APA's Engineering team, as not all solutions are allowed on every site.

[1] Use a steel tape rather than a fiberglass tape to measure distances over the length of the row. Fiberglass can stretch over time and affect layout and installation lengths.

[2] With extreme topography, every foundation must be marked and the string line must be attached to every foundation in order to ensure that the racking will flow at every high and low point.

[3] Install the beginning, middle and end foundations about half of the way to depth (typically until threads are not showing). Then attach a string line to these installed foundations, creating a straight line for the installation process. This will give the installer a guide and ensure that the foundations are plumb.

[4] If holes are pre-drilled, they must be filled with aggregate immediately, ensuring debris or water doesn't fall into the holes. If this happens, a void can be created causing the foundations to possibly sink in the future.

[5] Try to avoid using the top interior and bottom exterior holes in the riser for the connection points. This will help avoid connection interference.

OPERATION & MAINTENANCE

Regular inspections and proper maintenance are essential to maintain the design life and warranty of the A-Frame® tracker foundation system. Solar racking is exposed to many elements from initial construction to seasonal changes and can even be susceptible to severe weather conditions. The following Operation and Maintenance procedures should be followed and performed on an annual basis to ensure the warranty for the racking system remains active. The procedures below highlight the critical points to be examined and maintained for a properly functioning solar racking system.

BOLTED CONNECTIONS

Bolted connections need to be visually inspected annually to ensure the components are properly joined together. There are torque marked nuts/bolts at the beginning, middle, and end of each row per the APA QA/QC process. These marked locations should be visually inspected to confirm no movement of the bolted connections have occurred. If loose hardware is found, re-tighten to the specifications noted in the plan set for the racking system.

SOLAR PANEL CLAMPS

Clamps need to be visually inspected annually to ensure modules are properly secured. If loose clamps are found, re-tighten to the specifications noted in the plan set for the racking system.

GALVANIZE COATING

The galvanized coating ensures that the steel components are protected from corrosion and that the solar racking system will last for the entire project life. The solar racking system should be inspected annually for any areas of corrosion or rust. If areas are found, they should be repaired in a timely manner by cleaning the area, then generously applying cold galvanizing compound.

The cut, slit and sheared edges of the racking system are exposed steel that are expected to show corrosion or rust. This is normal and should be expected, but does not affect the structural integrity of the system.

Copper should be isolated and cannot touch the galvanized coating, as it will expedite corrosion.

CROSS BRACING CABLE WIRE

If applicable to your project, the bracing needs to be visually inspected on an annual basis to ensure that it has not become loose. Cables are required to be taut for limiting motion, but do not need to be tensioned.

SYSTEM DAMAGE

The solar racking system should be visually inspected for other types of damage. Examples include damage from mowing equipment, maintenance equipment, falling trees or branches, storm damage, system lean, soil erosion, etc. Any components that are damaged or deformed should be replaced as they may be weaker or corrode faster than intended. Some components may be able to be repaired onsite if replacement is not practical. Contact APA for assistance with replacement parts or instructions on repairing a component.

GENERAL OPERATION

It is important to maintain the solar racking system to ensure the design lifespan.

Keep all vegetation managed and off of the racking system and solar modules.

Check that module cleaner solution, weed killer, or other chemicals used on or around the solar racking system are not corrosive to galvanized or stainless steels.

Check electrical wiring to ensure it is managed properly and protected.

Take note and log when inspections were performed and if any corrective actions were taken or need to be taken in the future.

ANNUAL A-FRAME® O&M

This Addendum is to serve as guidance for inspecting hardware during annual O&M to maintain the designed lifespan of APA Solar Racking's A-Frame® product.

ANNUAL REQUIREMENTS FOR PROJECTS <10MW

- A Minimum of 3% of torqued connections shall be checked (checks should be done evenly across the site, hitting exterior and interior rows, as well as standard, damper, and motor A-Frames®).
- Torque checks should be done to the minimum torque value to avoid breaking the lock tight connection.
- Visually Inspect all connections on exterior rows.
 - Foundation set bolts should be visually inspected for engagement.
- If connections are found loose or below the minimum torque value, Blue Loctite 242 should be applied to the bolt and retorqued to a minimum of 25ft-lbs.
 - If hardware is damaged, it should be replaced and torqued to spec.

ANNUAL REQUIREMENTS FOR PROJECTS 10MW-25MW



- A Minimum of 1% of torqued connections shall be checked (checks should be done evenly across the site, hitting exterior and interior rows, as well as standard, damper, and motor A-Frames®).
- Visual inspections shall be done on 5% of torqued connections.
- Torque checks should be done to the minimum torque value to avoid breaking the lock tight connection.
- Visually Inspect all connections on exterior rows.
 - Foundation set bolts should be visually inspected for engagement.
- If connections are found loose or below the minimum torque value, Blue Loctite 242 should be applied to the bolt and retorqued to a minimum of 25ft-lbs.
 - If hardware is damaged, it should be replaced and torqued to spec.

ANNUAL REQUIREMENTS FOR PROJECTS >25MW

- A Minimum of 0.5% of torqued connections shall be checked (checks should be done evenly across the site, hitting exterior and interior rows, as well as standard, damper, and motor A-Frames®).
- Visual inspections shall be done on 5% of torqued connections.
- Torque checks should be done to the minimum torque value to avoid breaking the lock tight connection.
- Visually Inspect all connections on exterior rows.
 - Foundation set bolts should be visually inspected for engagement.
- If connections are found loose or below the minimum torque value, Blue Loctite 242 should be applied to the bolt and retorqued to a minimum of 25ft-lbs.
 - If hardware is damaged, it should be replaced and torqued to spec.

GENERAL NOTES

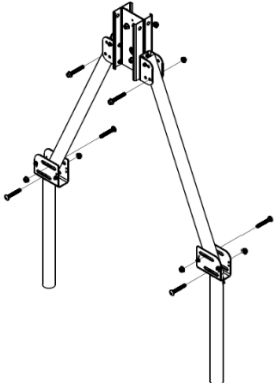
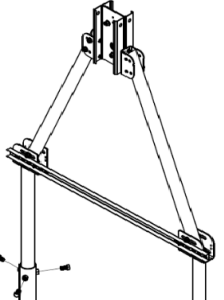
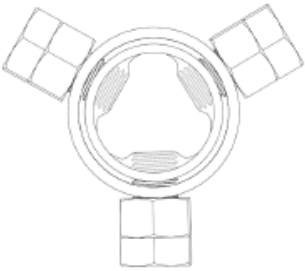
- Torque checks shall be performed with a torque wrench with a valid calibration certificate.
- Place the torque wrench on the nut side of the bolted connections with a wrench on the bolt head when checking torque.
- If a pattern of under-torqued connections is found, checks shall be expanded beyond the minimum requirements to identify the affected area.
- Refer to APA Solar Racking's Installation Manual for other annual O&M requirements.
- Tracker components shall be checked according to the tracker manufacturers O&M specifications.

	<p>Torque Check all (8) 1/2" bolt connections to the minimum torque value of 25ft-lbs.</p>
	<p>If rigid cross bracing is used on the site, ensure the brace sits snug and flush against the flat face of the leveling flanges. Ensure all (4) hardware connections are present. This is a visual inspection only as this hardware does not have a torque spec.</p>
	<p>Proper engagement of the foundation set bolts is for the bolt head to be fully seated against the nuts. There is no torque value for this connection as it is an interference fit.</p>
	<p>Torque marks are to cross the end of the bolt, down the bolt threads, across the nut, and onto the material surface, in a straight line.</p>

FOUNDATION INSTALLATION

- [1] EARTHLOCK OR USA GROUND SCREW FOUNDATION
- [2] FOUNDATION COLLAR ASSEMBLY
- [3] DRIVE HEAD & PIN

1. Insert the drive pin into the foundation and slide the drive head over the end of the foundation.
2. Drive the foundation with a single point, starting at one end of the site. The string line method is best for ensuring a straight line and a perfect plane of the array. Foundations are to be installed with a maximum reveal of 6" above grade.
3. Ensure the foundation is held plumb and in the proper location using a level.
4. Drive the foundation to the correct depth as indicated by the construction documents.
5. Install all remaining foundations, using a string line as a guide for placement and height if necessary. Use a tape measure as described in the preparation process.
6. Once foundations have been installed, slide the collar over the screw and tighten in accordance with the racking system's installation process. Note: the collar can be slightly tightened to hold it in place but if it is over tightened, it can interfere with the racking installation.

ALTERNATE FOUNDATION INSTALLATION

For sites with medium-to-heavy rock or bedrock, holes may need to be piloted and backfilled prior to foundation install. Refer to the Ground Screw Install Procedure - Drilled Hole.

NOTE

Check all survey points before drilling.

NOTE

This addendum covers the installation of EarthLock™ (multi-part) Foundations and USA Ground Screws.

