

TITAN

3-RAIL DESIGN

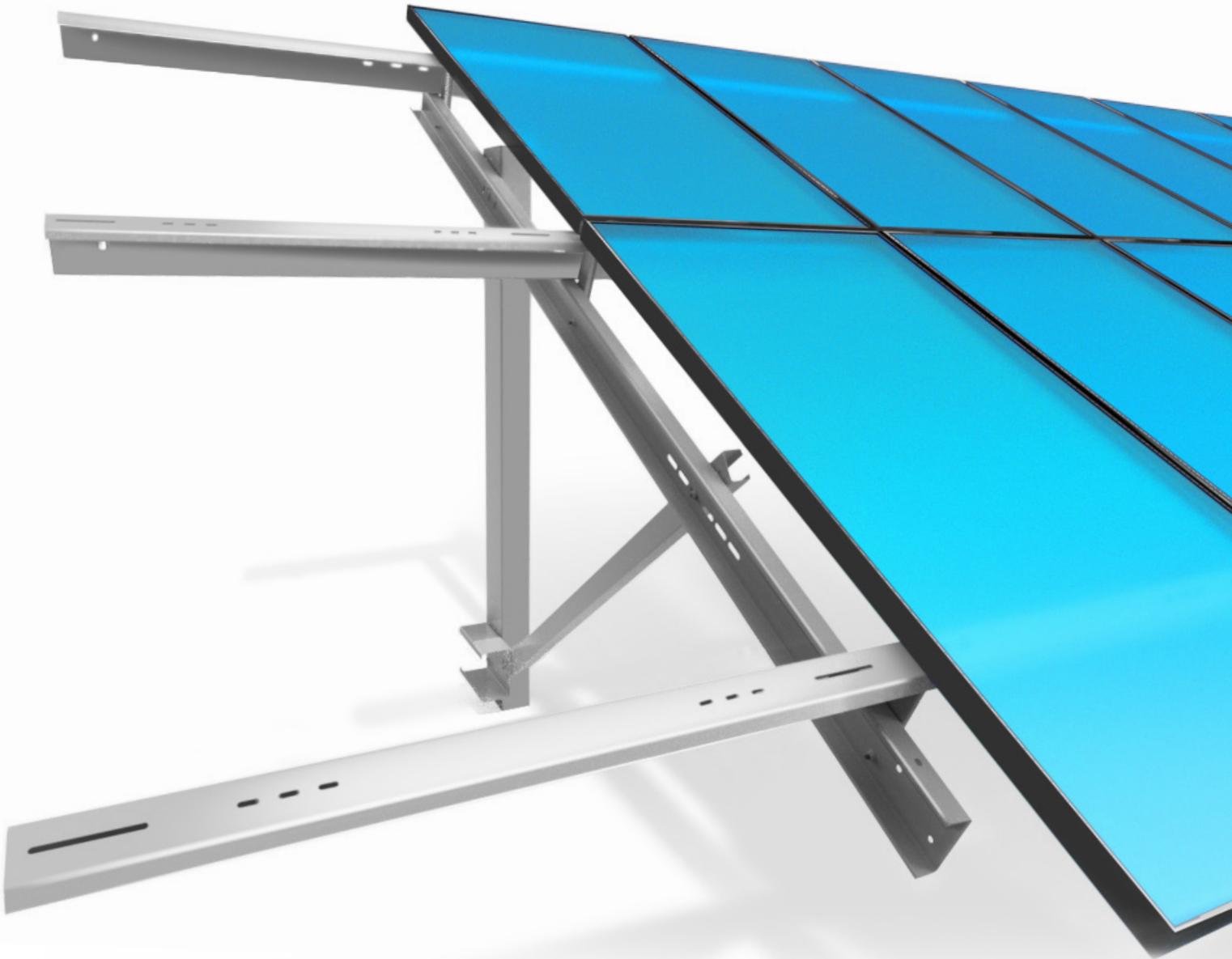

TABLE OF CONTENTS**PAGE**

2	TABLE OF CONTENTS
3	PARTS LIST
4	SITE PREPARATION, UTILITIES, SURVEYING, TOOLS
5	REVIEW & INSTALLATION PREPARATION, UNEVEN GROUND, MEASURING
6	FOUNDATION INSTALLATION
7	CEE GUSSET-TO-CEE PILE, ROLL BRACKET-TO-N/S CHORD
8	N/S CHORD-TO-CEE PILE, KNEE BRACE-TO-CEE GUSSET, KNEE BRACE-TO-N/S CHORD, ADJUSTMENTS
9	ZEE PURLIN STAGING, TRANSVERSE BRACE-TO-ZEE PURLINS
10	TRANSVERSE BRACE-TO-ZEE PURLINS (CONTINUED), ZEE PURLINS-TO-ROLL BRACKET
11	ADJUSTMENTS, ZEE PURLINS-TO-N/S CHORD, ZEE PURLIN-TO-ZEE PURLIN (SPLICE)
12	GRAVITY CLIP PREINSTALLATION, PANEL INSTALLATION
13	PANEL INSTALLATION (CONTINUED)
14	PRO-TIPS
15	O&M REQUIREMENTS

PARTS LIST

STRUCTURAL MEMBERS

- [1] CEE GUSSET
- [2] CEE PILE
- [3] ROLL BRACKET ASSEMBLY
2X 3/8-16X1.0" PUSH-IN STUD
- [4] N/S CHORD
- [5] E/W ZEE PURLIN
- [6] KNEE BRACE
- [7] TRANSVERSE BRACE

HARDWARE

- [8] 3/8-16 SERRATED FLANGE NUT
- [9] 1/2-13 SERRATED FLANGE NUT
- [10] 1/2-13X1.0" SERRATED FLANGE BOLT
- [11] END CLAMP ASSEMBLY
M8X1.25 25MM HEX BOLT
M8 LOCK WASHER
END CLAMP (SIZED FOR PANEL)
M8X1.25 SERRATED FLANGE NUT
- [12] GRAVITY CLIP ASSEMBLY
M8X1.25 70MM HEX BOLT
M8 LOCK WASHER
MID CLAMP
SPRING
GROUNDING SPACER
M8X1.25 SERRATED FLANGE NUT
- [13] MIDCLAMP ASSEMBLY
M8X1.25 70MM HEX BOLT
M8 LOCK WASHER
MID CLAMP
SPRING
GROUNDING SPACER
M8X1.25 SERRATED FLANGE NUT

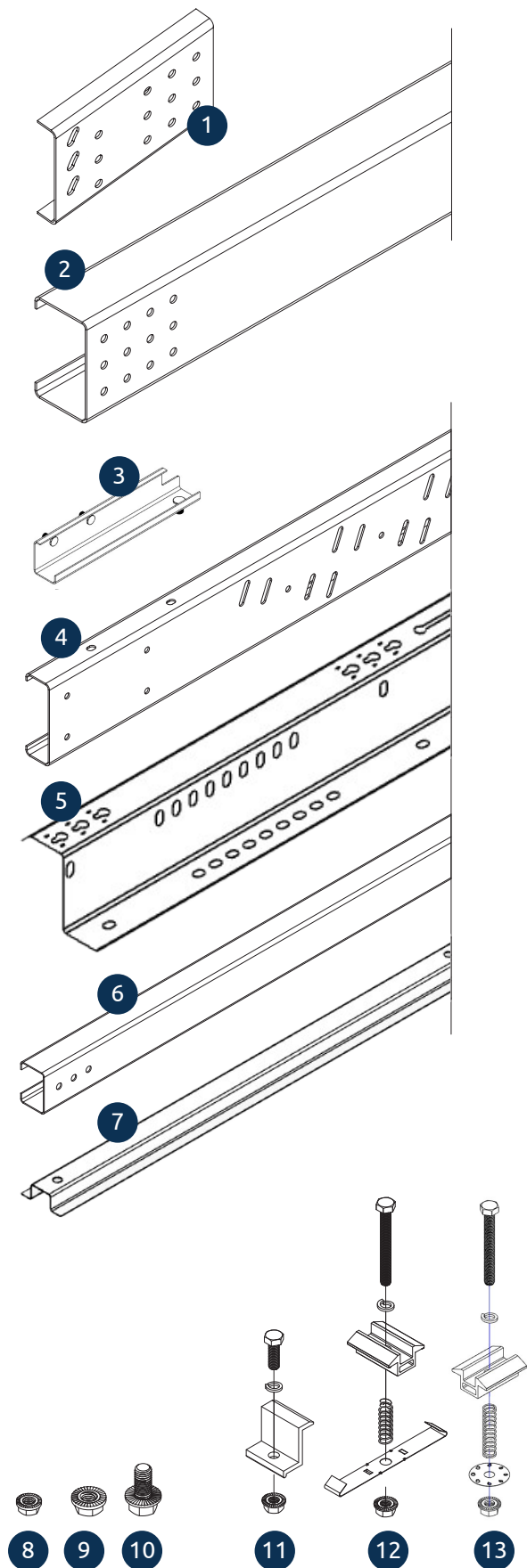

CONSTRUCTION 101

All structures, regardless of how complex, are built one step at a time. Each new step builds on the previous. In order for the final structure to be complete, it is best to ensure that each step is done correctly. It is far easier, faster, and cheaper to take your time to ensure each step is done correctly before moving on. There is no remedy for an error other than a correction. Time and effort will be put forth eventually to redo steps, reconstruct, and make adjustments, but far less effort is required to correct mistakes as they appear. If errors are fixed immediately, each subsequent step will begin correct and projects will run more efficiently.

It is recommended to completely install a test row from beginning-to-end of the row, and from beginning-to-end of all steps (from layout, to panel installation, and adjustments). This will help you understand not only how to install the product, but understand how tolerances stack up, how mistakes in one step cause errors in other steps, and how to make the adjustments required to keep everything in tolerance and looking good.

SITE PREPARATION

Site preparation should be conducted prior to construction. This will typically involve grubbing, rock and debris removal, and any other preparation that will facilitate swift and unhindered installation.

UTILITIES

All utilities should be marked before any construction begins.

SURVEYING

To ensure that the solar array is installed according to customer plans, the site should be surveyed according to the scope of work. This includes the cee pile foundation locations for the TITAN system. For projects with significant topography, survey points should be checked with a tape measure. Typically, the TITAN system requires a 100% survey.

TOOLS

1/2" hardware requires a minimum 300 ft/lb impact gun to have enough torque to tighten fully. 3/8" hardware requires a standard Dewalt impact driver or similar. Use a 15" spud handled tool for alignment of E/W rail. For module installation, use a standard impact gun with a maximum of 154 ft/lb torque.

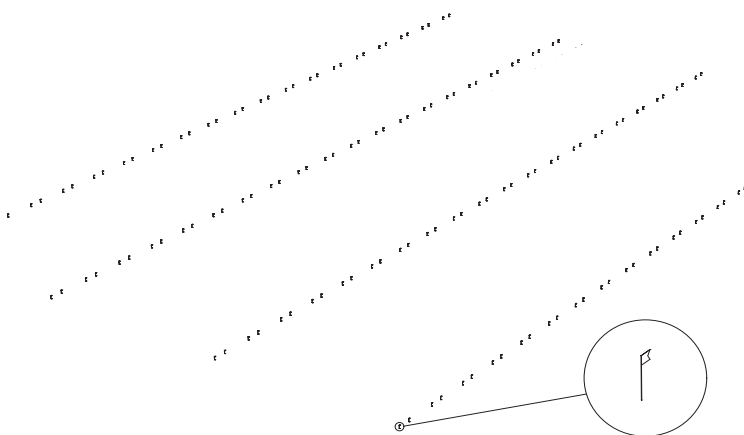

NOTE

Foundation locations should be surveyed by a professional surveyor, who can stake out row locations to the highest precision.

REVIEW & INSTALLATION PREPARATION

After site preparation has been completed and the site surveying is done, the foundations are ready to be installed. It is the responsibility of the site lead to review and understand the site foundation layout, surroundings, installation procedures, and to manage the installation to completion. Each project has different requirements (embedment depths, spans, etc.) that need to be met according to site testing and data gathered prior to the start of the project. The site lead must verify that the foundations on site match the order and project requirements.

Dimensions in the East-West direction will change depending on row length, row location, and location within the row. Closely follow the construction plans and if there are any questions or discrepancies, report them to the site lead or project manager before installing any foundations.

UNEVEN GROUND

For sites with ungraded or rolling topography, it is important to ensure that the foundations are set to the correct depths. In cases where foundation locations can not be marked on the ground (uneven terrain), it is advised to check the survey points with a steel tape measure.

MEASURING

All measurements in the East-West direction must be made with a steel tape measure, and made from the start of the row, not foundation-to-foundation. For example, if the plans were to call for the first 4 spans to be 100" each, the tape should be staked to the ground, and the ground should be marked at 0", 100", 200", 300", 400".

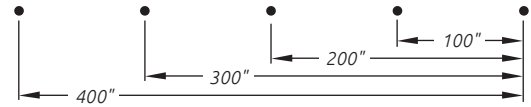

Measuring from foundation-to-foundation allows tolerances to stack up. In this case, a 2" tolerance would have stacked up to be 8" off by only the fifth foundation, and will cause major installation issues further down the road. If necessary, tape measures should be marked prior to use or prints should be marked up to indicate additive measurements (ie. 0", 8'4", 16'8", 25'0", 33'4").

PRO TIP
I

FOUNDATION INSTALLATION

1. Install the first foundation, starting at one end of the site. Align the Northwest corner of the cee pile with the location marker. The string line method is best for ensuring a straight line and a perfect plane of the array.
2. Ensure that the end with the hole pattern is is at the top and that the cee pile is plumb.
3. Using a pile driver, drive the foundation to the correct embedment depth as indicated in the construction documents.
4. Repeat further down the row with another foundation to create the next attachment point for the string line, once again measuring and ensuring plumbness. When topography is present, additional transition foundations must be installed at transition points so that the string line can flow through hills and valleys at a moderate rate. Although the racking will follow terrain, it has limitations. Therefore, ensuring smooth flow will greatly aid the installation process.
5. Continue to the end of the row as required to set a string line.
6. Run a string line between all foundations at the same height. For consistency, string line should run along the same side of the foundation for the entirety of the site (for example, always wrap counterclockwise, then install new foundations on the South side of the string). This will help prevent zigzagging.
7. Ensure the heights of all foundations are correct and flow with the terrain in the method indicated in the construction plans.
8. Install all remaining foundations, using a string line as a guide for placement and height if necessary. Use a tape measure as described in the preparation process.

Northwest corner of cee pile aligns to survey point

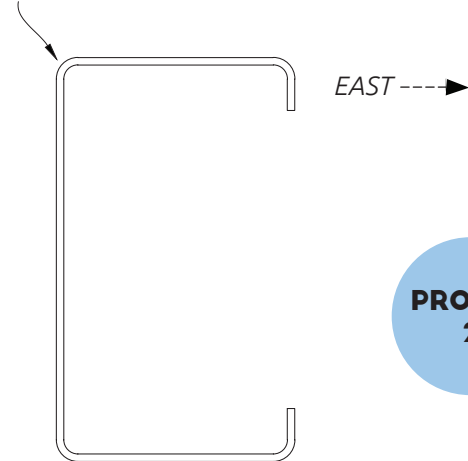

PRO TIP 2

PRO TIP 3

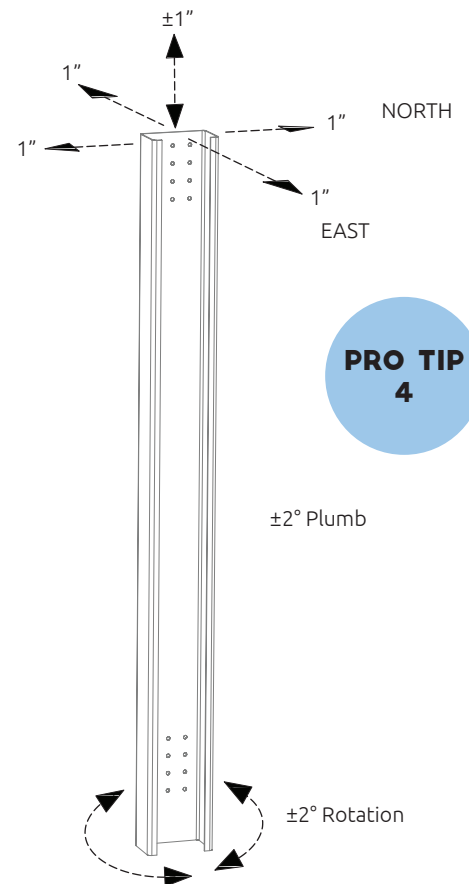

PRO TIP 4

±2° Plumb

±2° Rotation

PRO TIP 5

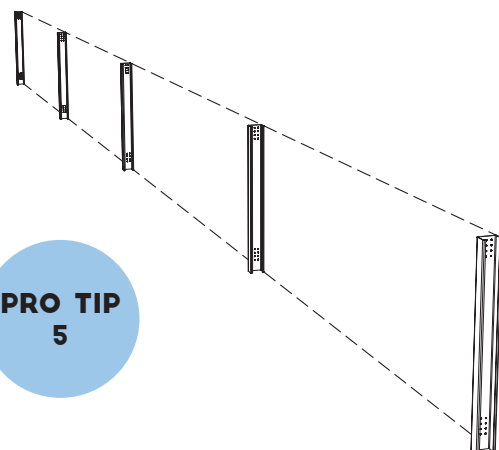

CEE GUSSET-TO-CEE PILE

1. Align the flat side of the gusset to the flat side of the pile. Ensure the gusset is overhanging at the front (South) side of the cee pile.
2. At the two nominal locations indicated in the construction documents, place a bolt through each hole and secure with a nut. Fasten loosely.
3. Additional holes in the cee gusset and cee pile are for adjustments.

- [1] CEE GUSSET
- [2] CEE PILE
- [9] 1/2-13 SERRATED FLANGE NUT
- [10] 1/2-13X1.0" SERRATED FLANGE BOLT

ROLL BRACKET-TO-N/S CHORD

1. Along the flat side of the N/S chord, with the slots on the N/S chord pointing up, attach a roll bracket assembly.
2. Match the two (2) studs in the roll bracket assembly in the correct hole set at the front of the part. Refer to site build plans to determine which set to use. Correct usage is based on specifications provided by the module manufacturer, and will remain consistent on each project (assuming only one module model is used).
3. Secure both studs, each with a nut.
4. Repeat steps for all remaining roll brackets. There are three (3) roll brackets per N/S chord.

- [3] ROLL BRACKET ASSEMBLY
- [4] N/S CHORD
- [8] 3/8-16 SERRATED FLANGE NUT

NOTE

Images are for reference only. Ideal hole/slot connection points may vary. It is recommended to loosely assemble hardware until final adjustments have been made. Then go back through and tighten all hardware. Stainless hardware may gall and be difficult to loosen after it has been tightened to torque specs.

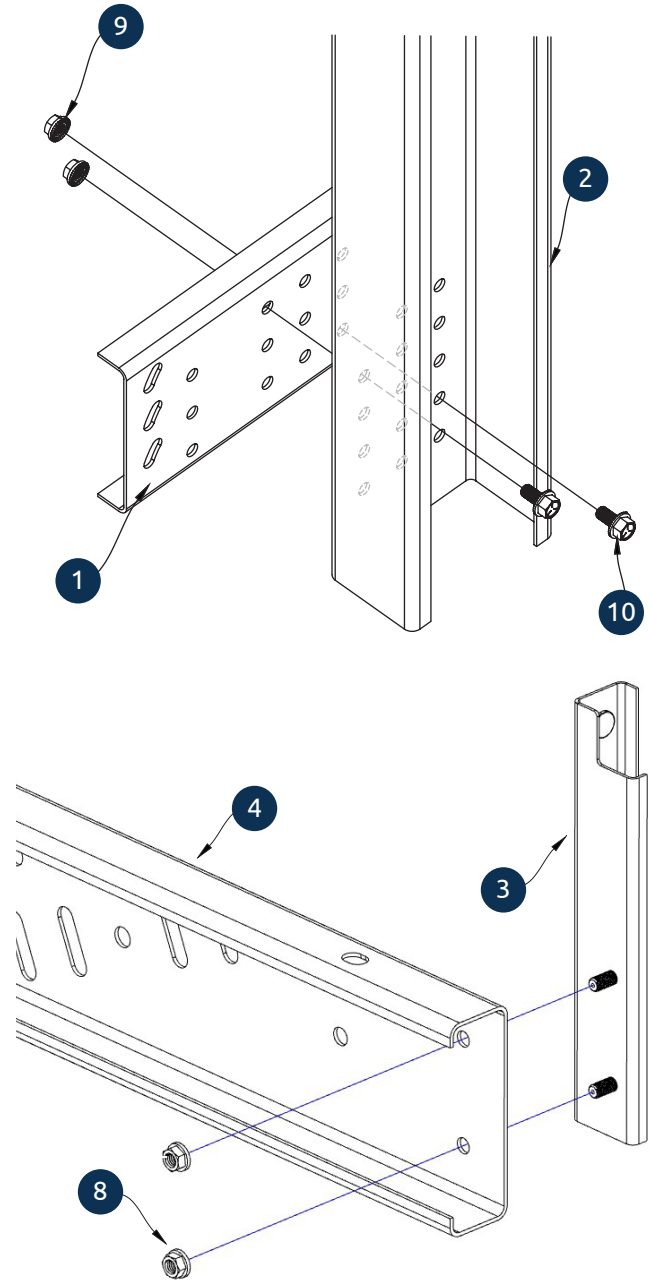

N/S CHORD-TO-CEE PILE

1. Ensure the N/S chord is on the West side of the pile, with the flat side against the flat side of the pile, and the smaller flange with slots is pointing upwards.
2. Attach with a bolt and nut through the single hole in the N/S chord and the nominal preferred hole in the cee pile as indicated in the construction documents. Fasten loosely.
3. Additional holes in the N/S chord and cee pile are for adjustments.

- [2] CEE PILE
- [4] N/S CHORD
- [9] 1/2-13 SERRATED FLANGE NUT
- [10] 1/2-13X1.0" SERRATED FLANGE BOLT

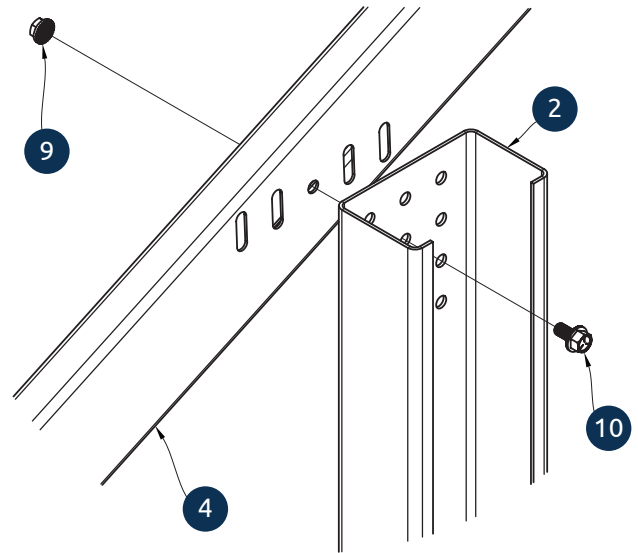

KNEE BRACE-TO-CEE GUSSET

1. Attach the knee brace to the cee gusset using the hole/slot combination indicated in the construction documents. Each knee brace should be secured with two (2) bolts.
2. Secure with bolts and nuts. Fasten loosely.
3. Additional holes in the cee gusset and knee brace are for adjustments.

- [1] CEE GUSSET
- [6] KNEE BRACE

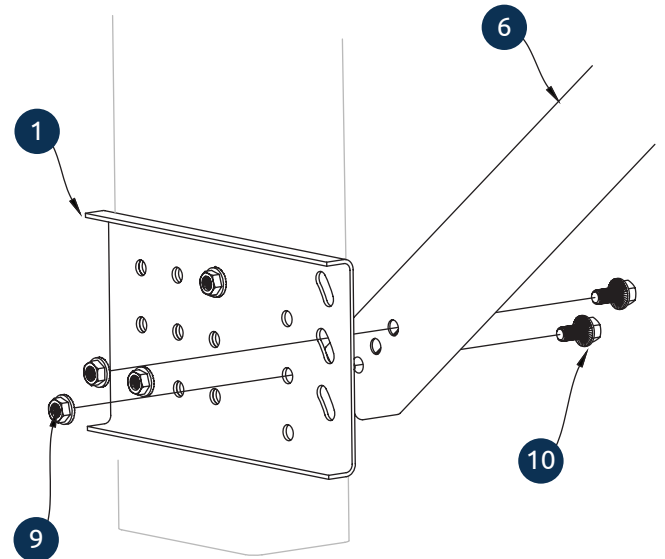

KNEE BRACE-TO-N/S CHORD

1. Attach the knee brace to the N/S chord using the hole/slot combination indicated in the construction documents. Each knee brace should be secured with two (2) bolts.
2. Secure with bolts and nuts. Fasten loosely.
3. Additional holes in the knee brace and N/S chord are for adjustments.

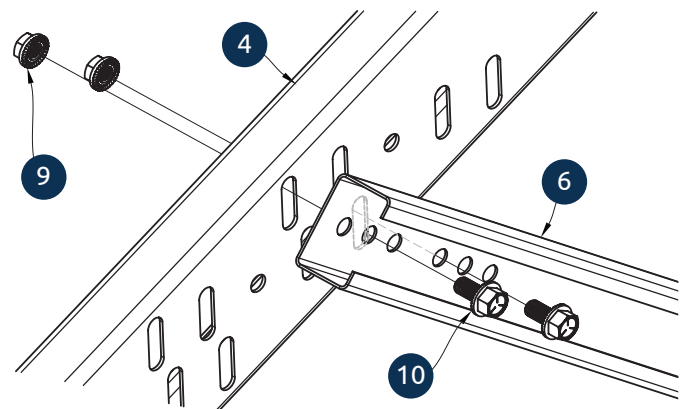

ADJUSTMENTS

1. Sighting down a row, looking from East or West, check for inconsistencies in the heights of the racking. Adjust the height by removing the N/S chord hardware and adjusting the height using the adjustment holes before re-attaching the hardware. Fully tighten all fasteners once adjustments have been made.

ZEE PURLIN STAGING

Stage the zee purlins by setting them on the N/S chord and resting above the roll brackets.

1. Refer to the build plans to ensure the correct zee purlins are in the correct position. There are differences in either length or hole pattern in the zee purlins, so ensure the correct part number is used. There typically are multiple zee purlins of the same length, with only slightly different hole patterns.
2. Ensure the zee purlins are in the correct orientation with the slotted side facing up and towards the front of the rack.

TRANSVERSE BRACE-TO-ZEE PURLINS

1. Install the transverse braces to the zee purlins at the locations required per the construction plans. Braces are always installed in sets of two (2); one pointing East, and one pointing West. Braces are required at the first and last purlin splice on each row, and at increments required per the construction documents.
2. Starting at the South most zee purlin splice, fasten the transverse brace to the zee purlin through the outer-most lower slot of the zee purlin. The holes in the transverse brace must face up, but the orientation (which direction the flanges point) is unimportant. The correct hole in the transverse brace must also be used. This is dependent on the location of the roll bracket (inner or outer) and will be indicated on the construction documents. If the roll brackets are installed in the outer location, the outer-most holes at each end of the transverse brace are used. If the roll brackets were installed at the inner location, the middle holes in the transverse brace should be used.
3. Secure with a bolt and nut (ensuring the bolt is facing down). Fasten loosely.

- [5] E/W ZEE PURLIN
- [7] TRANSVERSE BRACE
- [9] 1/2-13 SERRATED FLANGE NUT
- [10] 1/2X1.0" SERRATED FLANGE BOLT



Example zee purlin layout

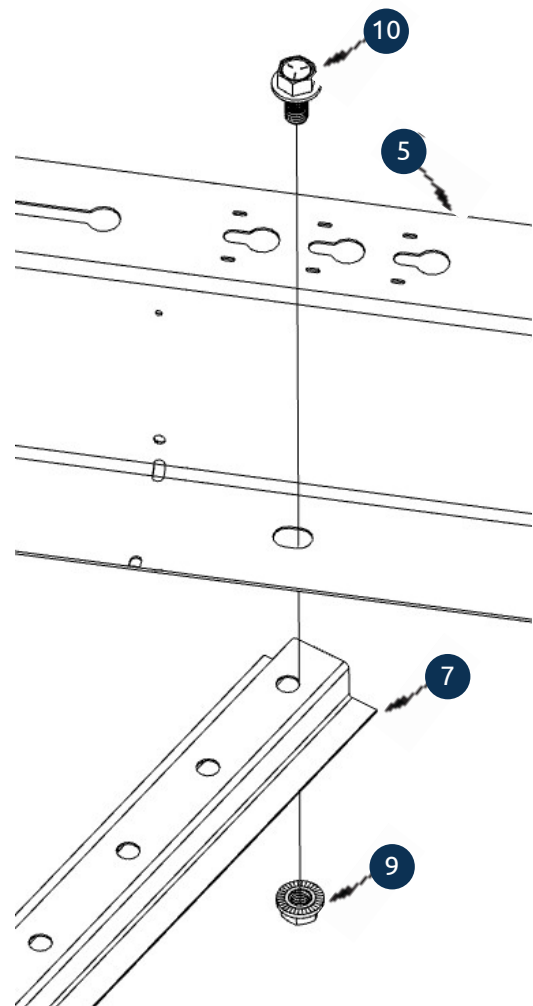

TRANSVERSE BRACE-TO-ZEE PURLINS (CONTINUED)

4. Repeat at the opposite end of the transverse brace, directing the brace away from the zee purlin splice. There is a solo slot approximately 5' from the outer zee purlin splice hole. Fasten through this hole using the outer or middle hole in the transverse brace (same as step 2).
5. Finally, fasten the transverse brace to the middle zee purlin using the middle hole of the middle set of holes in the transverse brace.
6. Repeat steps 2-5 and install the matching transverse brace on the opposite side of the zee purlin splice, and angle it in the opposite direction.
7. Repeat steps 2-6 for all remaining braces as indicated on the construction documents.

NOTE

Transverse braces are not for squaring the structure but to minimize transverse movement (racking) and keep the rack square. If the rack is not square to begin with, the transverse braces will not fit or function correctly. If different holes than outlined here must be used, the rack is not square and further installation of the panels will not be correct. Ensure transverse braces are installed prior to panels installation.

ZEE PURLINS-TO-ROLL BRACKET

1. Ensure the stud goes through both zee purlins.
2. The stud should typically go through the center slot (4th slot) on both purlins. Occasionally, the other slots may need to be used to resolve foundation installation errors.
3. Secure with a nut. Fasten loosely.
4. Repeat at all locations for each N/S chord. There are three (3) roll brackets and connections required per N/S chord.

- [3] ROLL BRACKET ASSEMBLY
- [5] E/W ZEE PURLIN
- [9] 1/2-13 SERRATED FLANGE NUT

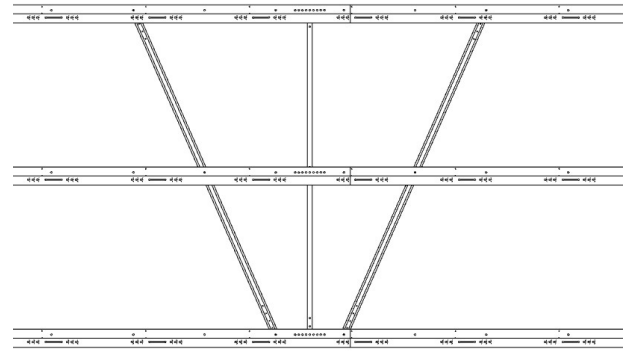

Roll Brackets (and Zee Purlins) set to outer holes, use brace outer holes

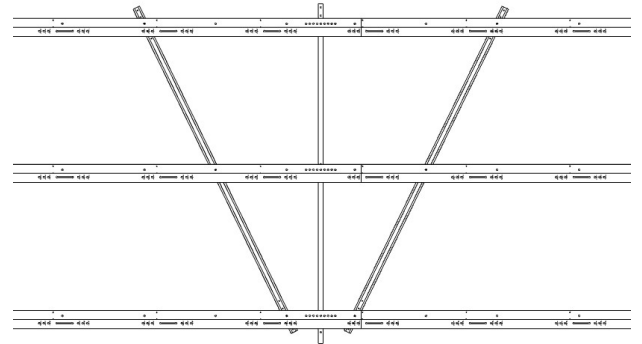

Roll Brackets (and Zee Purlins) set to inner holes, use brace inner holes

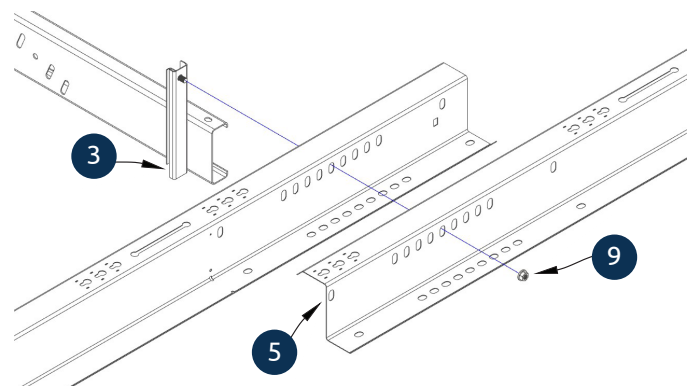

ADJUSTMENTS

1. The middle zee purlin should visually align when sighted East to West. Use the roll bracket adjustment holes on the N/S chord to move the zee purlin if necessary.

[3] ROLL BRACKET ASSEMBLY

[4] N/S CHORD

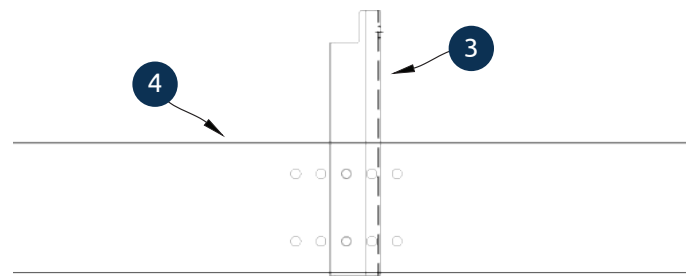

ZEE PURLINS-TO-N/S CHORD

1. The zee purlins should already be in the correct location and loosely fastened by now.

2. Fasten the zee purlins to the N/S chord with a bolt and nut. Ensure the bolt is facing down (to keep wire tray clear). Fasten loosely.

Note: the lower slots are matched to the middle slots, so there is no choice in slots at this point. See note about nominal slots in the ZEE PURLIN STAGING step on page 9.

3. Repeat at all locations for each N/S chord. There are three (3) connections required per N/S chord.

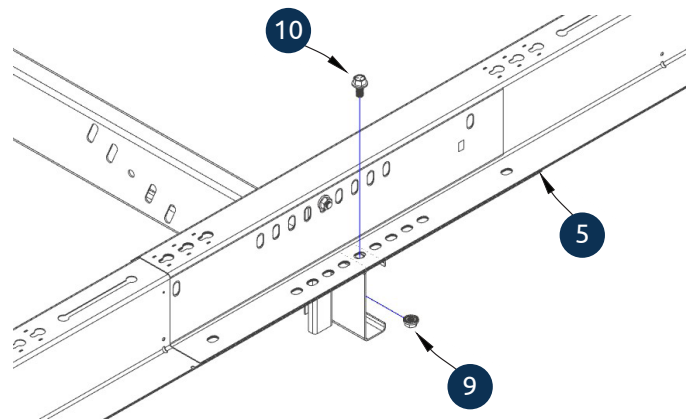

ZEE PURLIN-TO-ZEE PURLIN (SPLICE)

1. Splice the zee purlins together once the transverse braces are installed and the purlins are attached to the N/S chords.

2. Each zee purlin splice should have four (4) additional bolts at each location. Ideally, these should be at the outer-most slots at the center web and on the lower flange of the zee purlins.

3. If the zee purlin splice is already connected at the lower flange with a transverse brace, only the two (2) connections in the center web are needed. If the N/S chord is located at either outer-most hole, those zee purlin splice bolts should be moved inward one (1) set. All zee purlin splices should have six (6) connections total.

4. Secure each with a bolt and nut. Fasten loosely.

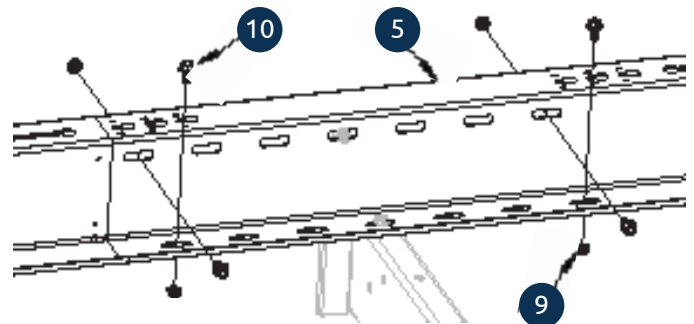

[5] E/W ZEE PURLIN

[9] 1/2-13 SERRATED FLANGE NUT

[10] 1/2X1.0" SERRATED FLANGE BOLT

PRO TIP
6

GRAVITY CLIP PREINSTALLATION

1. On the center zee purlin, install the gravity clip assembly.
2. Refer to the construction documents for the precise locations of where the gravity clip assemblies are required. Two gravity clip assemblies are required per panel which are shared with the panel above or below it.
3. Gravity clip assemblies should typically only be installed in the short keyslots. There are three short keyslots for each set. Refer to construction documents for correct slot usage.
4. Install by holding the assembly with the nut down towards the zee purlin.
5. Push the nut through the large hole in the keyslot, and slide the assembly over until the two tabs on the gravity clip engage with the two slots above and below the keyslot. This keeps the gravity clip in place and prevents rotation and movement in further steps.
6. If needed, rotate the midclamp so that the long side aligns with the zee purlin. Do not tighten.
7. Install all remaining gravity clip assemblies for the row.

[5] E/W ZEE PURLIN

[12] GRAVITY CLIP ASSEMBLY

PANEL INSTALLATION

1. Starting at one end, begin hooking the pv modules on the gravity clip. Refer to the construction documents to determine the correct orientation of the module to correctly align the junction boxes at the rear of the module.
2. Stage the first lower module by hanging the module on the lower hooks of the first two preinstalled gravity clip assemblies. Start in the middle of the keyslot.
3. Stage the upper module directly above the lower module, ensuring the module aluminum frame is against the gravity clip. Failure to ensure a good fit may result in the grounding teeth not engaging properly.

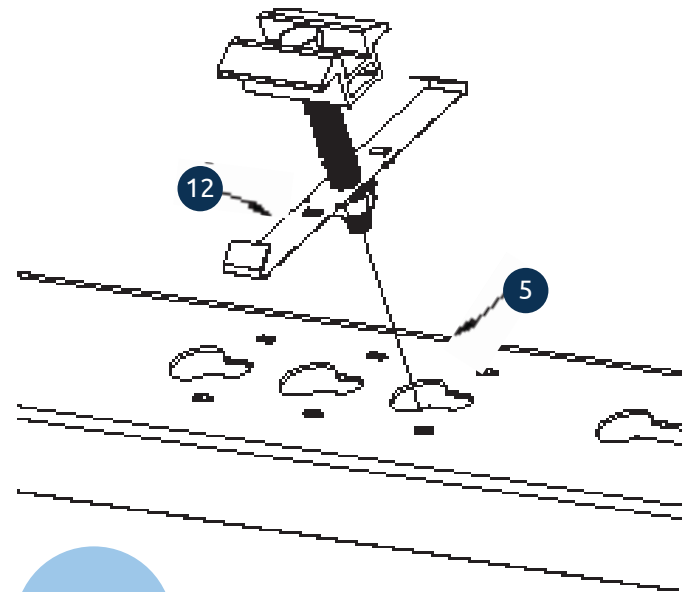

PRO TIP
7

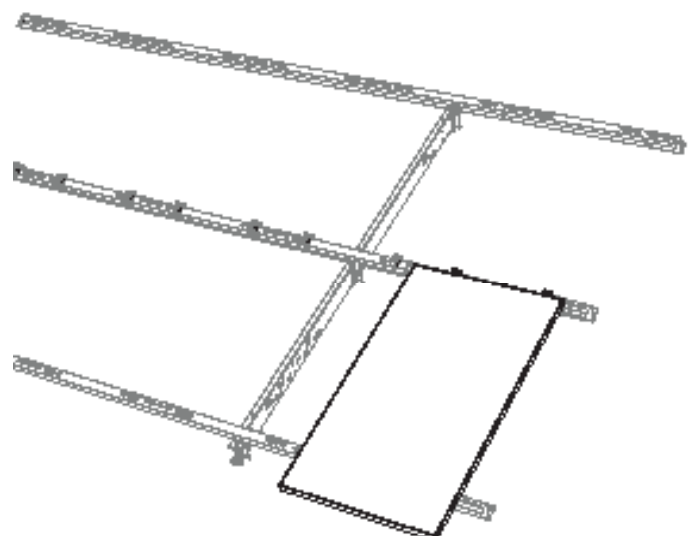
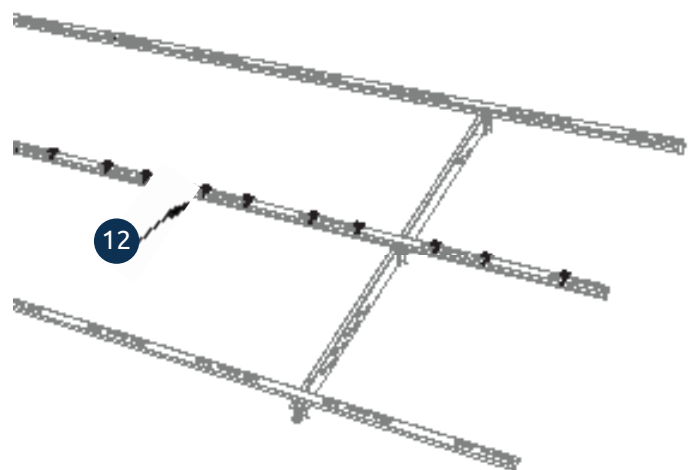

PRO TIP
8

PANEL INSTALLATION (CONTINUED)

4. Align the long edges of the modules so they are flush.
5. Install an end clamp at the beginning, on both the top and bottom modules, in the long keyslot. Keep loose.
6. Install midclamp assemblies on the inner edges of the top and bottom modules, typically in the long keyslots. Keep loose.

[11] END CLAMP ASSEMBLY

[13] MIDCLAMP ASSEMBLY

7. Continue staging modules and placing midclamp assemblies up to the reset point, which requires more end-clamps. Each time, stage the lower module, then upper module, then both midclamp assemblies.

8. Adjust the modules East to West until they are all in the correct place, and the long edges are flush and square.

9. Tighten the gravity clamp assemblies. One person should push the lower and upper modules up slightly so the module frame is against the side of the aluminum clamp on both the front and rear side. If the clamp is above the module frame, tighten assembly slightly to ensure frame does not touch the bolt/spring. Another person must tighten the nut from below the rack.

10. Tighten the endclamp assemblies.

11. Adjust and tighten remaining gravity clip assemblies and midclamp assemblies, each time ensuring that all modules are tight against the aluminum clamps both above/below and to the clamps to the sides.

12. Tighten endclamps. Ensure all grounding barbs are engaged in the aluminum module frames.

13. Repeat steps 1-12 to the end of the row, in sections. Reference your construction documents to determine the correct location of module clamps and end clamps.

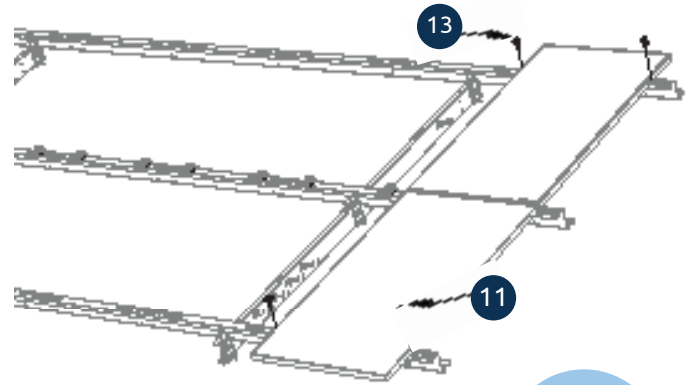

PRO TIP
9

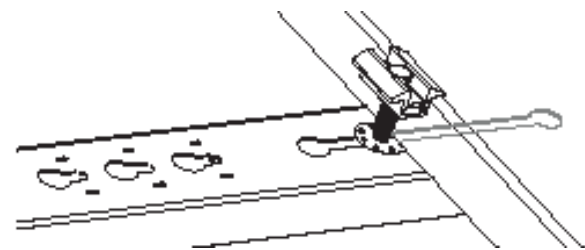

Midclamps may be preinstalled from either side of the long keyslot

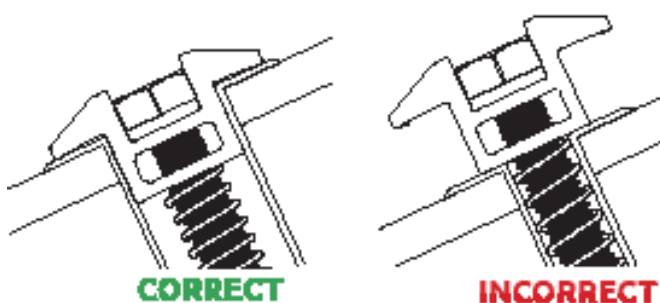
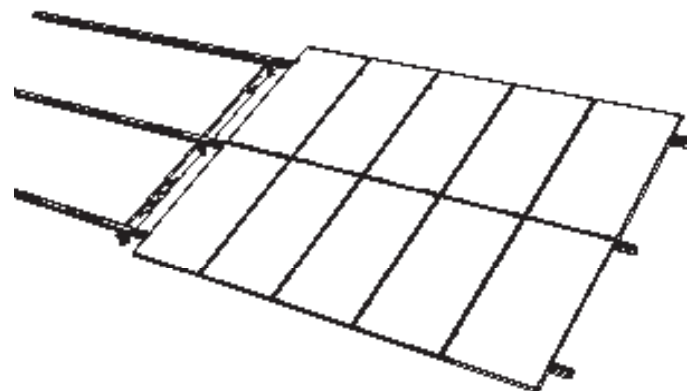

WARNING

DO NOT stage an entire row of modules. Only stage enough modules required to properly adjust them left to right (East to West). **DO NOT** leave modules unattended with untightened clamps, as wind may blow them off and cause damage.

PRO TIPS

PRO TIPS are pieces of advice from installation experts. They are intended to provide practical solutions to real-world problems that you may encounter. Before implementing any of the below tips, make sure to request approval from APA's Engineering team, as not all solutions are allowed on every site.

[1] Use a steel tape rather than a fiberglass tape to measure distances over the length of the row. Fiberglass can stretch over time and affect layout and installation lengths.

[2] With extreme topography, every foundation must be marked and the string line must be attached to every foundation in order to ensure that the racking will flow at every high and low point.

[3] Use a string offset from the piles to help alignment.

[4] While it is very difficult to make every foundation perfectly plumb and at the correct height, care should be taken to keep them within the tolerances specified in the plans in order to ensure that the system fits and functions as intended.

[5] When dealing with extreme topography, additional transitions will have to be added to make the racking flow with the terrain.

[6] Use a spud wrench to align keyhole slots while installing the overlapping zee purlins. Use a spud wrench/alignment punch to pry onto the stud. At times, due to topography, the opposite side of the zee purlin will have to be lifted in the air to properly seat onto the previously installed zee purlin.

[7] When staging panel clamps, tighten the bottom nut until the spring is slightly compressed. This will help the panel installer free up one hand. If the spring is not compressed prior to staging, the clamp will spin and another installer will have to hold the panel.

[8] When determining the position in the keylot, start in the middle. Adjust left or right moving through the row. It will change based on topography or achieving certain aesthetics.

[9] To square the panel, measure the distance from the edge of the panel to the flat part of the zee purlin on both sides, ensuring equal distance.

OPERATION & MAINTENANCE

Regular inspections and proper maintenance are essential to maintain the design life and warranty of the TITAN solar racking system. Solar racking is exposed to many elements from initial construction to seasonal changes and can even be susceptible to severe weather conditions. The following Operation and Maintenance procedures should be followed and performed on an annual basis to ensure the warranty for the racking system remains active. The procedures below highlight the critical points to be examined and maintained for a properly functioning solar racking system.

BOLTED CONNECTIONS

Bolted connections need to be visually inspected annually to ensure the components are properly joined together. There are torque marked nuts/bolts at the beginning, middle, and end of each row per the APA QA/QC process. These marked locations should be visually inspected to confirm no movement of the bolted connections have occurred. If loose hardware is found, re-tighten to the specifications noted in the plan set for the racking system.

SOLAR PANEL CLAMPS

Clamps need to be visually inspected annually to ensure modules are properly secured. If loose clamps are found, re-tighten to the specifications noted in the plan set for the racking system.

GALVANIZE COATING

The galvanized coating ensures that the steel components are protected from corrosion and that the solar racking system will last for the entire project life. The solar racking system should be inspected annually for any areas of corrosion or rust. If areas are found, they should be repaired in a timely manner by cleaning the area, then generously applying cold galvanizing compound.

The cut, slit and sheared edges of the racking system are exposed steel that are expected to show corrosion or rust. This is normal and should be expected, but does not affect the structural integrity of the system.

Copper should be isolated and cannot touch the galvanized coating, as it will expedite corrosion.

CROSS BRACING CABLE WIRE

If applicable to your project, the bracing needs to be visually inspected on an annual basis to ensure that it has not become loose. Cables are required to be taut for limiting motion, but do not need to be tensioned.

SYSTEM DAMAGE

The solar racking system should be visually inspected for other types of damage. Examples include damage from mowing equipment, maintenance equipment, falling trees or branches, storm damage, system lean, soil erosion, etc. Any components that are damaged or deformed should be replaced as they may be weaker or corrode faster than intended. Some components may be able to be repaired onsite if replacement is not practical. Contact APA for assistance with replacement parts or instructions on repairing a component.

GENERAL OPERATION

It is important to maintain the solar racking system to ensure the design lifespan.

Keep all vegetation managed and off of the racking system and solar modules.

Check that module cleaner solution, weed killer, or other chemicals used on or around the solar racking system are not corrosive to galvanized or stainless steels.

Check electrical wiring to ensure it is managed properly and protected.

Take note and log when inspections were performed and if any corrective actions were taken or need to be taken in the future.